



500 SERIES (BRONZE)

Magnetic Drive Positive Displacement Disc Meters Sizes 1 1/2" & 2"

FEATURES

Applications: Measurement of cold water for residential, commercial and industrial applications where water volumes are low, and low flow sensitivity is important.

Conformance to Standards: Mueller Series 500 Water Meters comply with ANSI / AWWA Standard C700, NSF-61 372 and the Safe Water Drinking Act. Each meter is tested to ensure compliance.

Construction: Mueller Series 500 Water Meters consist of three basic parts: maincase; measuring chamber; and permanently sealed register. The maincase and topcase are made of bronze. The measuring chamber, nutating disc and strainer are made of thermoplastic, which is dimensionally stable and will not corrode. A test port in the body permits in-line testing. Register box and lid are available in plastic or bronze for visual read registers

The meter is designed so that the register, measuring chamber and strainer can be replaced without removing the meter from the line.

Register: The permanently sealed register has a unique seal and heat-treated glass to eliminate dirt, moisture infiltration and lens fogging. An integral tamper-proof locking feature is provided to resist tampering with the register. The totalizing register has a straight-reading odometer type display, a 360° test circle with center sweep hand and a low flow (leak) detector. Standard gearing is used, making registers interchangeable by size.

All Mueller Meter Models have electronic meter reading systems available for increased reading efficiency (see Meter Reading Systems.)

Operation: Water flows through the meter's strainer where any debris that could adversely affect meter accuracy or free operation is screened out. As the water enters, it fills a known volume of the measuring chamber on one or the other side of a movable disc that separates the chamber into two sections. As water enters it moves the disc (nutates), forcing a known volume of water out of the meter from the opposite side of the disc. The process repeats as the sections refill and empty in turn. The nutating action of the disc is coupled magnetically to the register to indicate the volume of water that passes through the meter. The large measuring chamber requires fewer nutations of the disc for each gallon measured, which helps to limit wear, reduce pressure loss and extend the life of the meter.

Maintenance: The Mueller Series 500 Water Meters are designed and manufactured to provide long service life with virtually no maintenance required.

Connections: Available with integral two-bolt oval flanges.



562 PD METER WITH VISUAL REGISTER

MATERIALS AND SPECIFICATIONS

Model Number	562 and 572
Sizes	1 1/2" and 2"
Standards	Manufactured and tested to meet or exceed all applicable parts of ANSI / AWWA C700 Standard. NSF-61 372 and the Safe Water Drinking Act
Operating Flow Range	Cold water measurement with flow in only one direction
Accuracy	See chart on following page
Pressure Loss	See chart on following page
Maximum Working Pressure	150 psi
Temperature Range	33°F to 100°F water temperature
Measuring Element	Nutating disc
Disc Nutations (Per Gallon)	562: 6.47, 572: 3.92
Register Type	Straight reading, permanently sealed, magnetic drive with low flow indicator. Remote reading units optional. 2 Bolt Oval Flange
Materials	Maincase – No Lead Bronze; Measuring Chamber – Thermoplastic; Magnets – ceramic; Strainer – Thermoplastic; Casing bolts – stainless steel ANSI B18; Register box and lid – thermoplastic.
Options	Register box and lid – bronze UNSC85700; AMR / AMI Reading Systems.

500 SERIES

Magnetic Drive Positive Displacement Disc Meters Sizes 1 1/2" & 2"

METER REGISTRATION

METER SIZE	INITIAL DIAL*	CAPACITY	INITIAL DIAL*	CAPACITY
1 1/2"	100 Gallons	100 Million	10 Cubic Feet	10 Million
2"	100 Gallons	100 Million	10 Cubic Feet	10 Million

*Registration equal to one full revolution of the sweep hand.

FLOW CHARACTERISTICS

METER SIZE	TYPICAL LOW FLOW (95% MINIMUM)	TYPICAL OPERATING RANGE (100% ± 1.5%)	MAXIMUM CONTINUOUS OPERATION
1 1/2"	1 1/2 GPM	5 to 100 GPM	50
2"	2 GPM	8 to 160 GPM	80

PERFORMANCE

Head Loss - 1 1/2" and 2" (Figure 1)

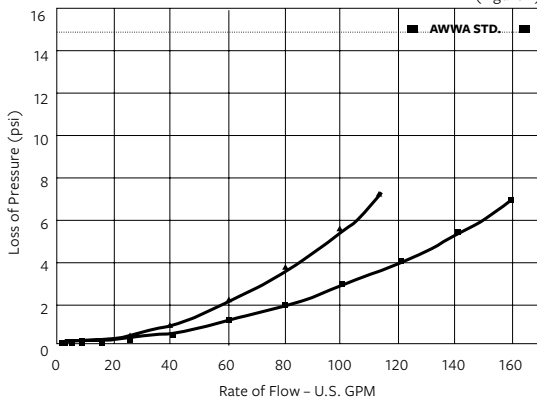

Accuracy - 1 1/2" AND 2" (Figure 2)

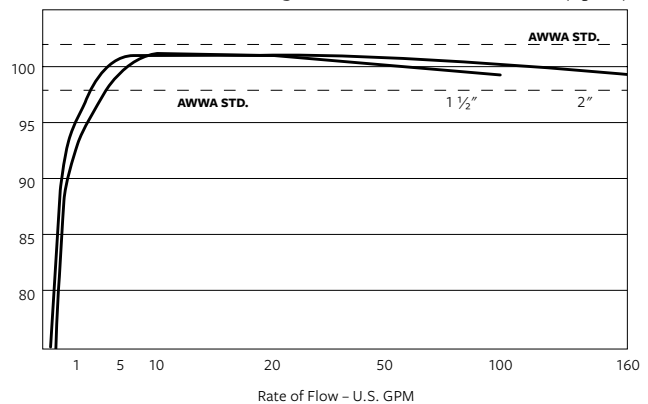

Note: Performance curves are typical only and NOT a guarantee of performance.

DIMENSIONS AND WEIGHTS

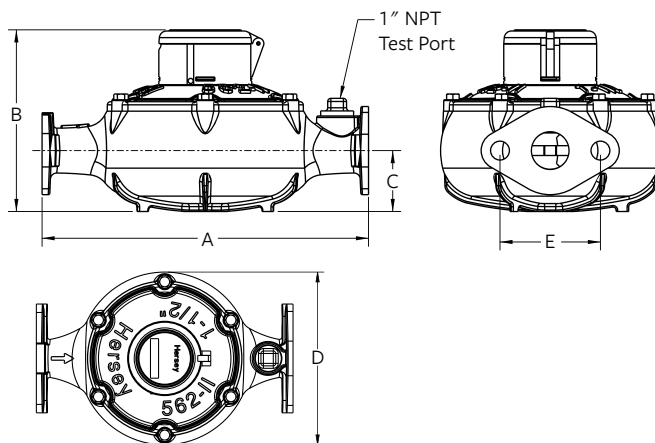

METER SIZE	1 1/2"	2"
ENDS	TWO BOLT FLANGED	
MODEL	562	572
DIMENSION		
A	13"	17"
B Visual Reg	7.250"	8.125"
B SSR Reg	7"	
B ME-8 Reg	7.75"	
C	2.437"	3.00"
D	8.750"	10.437"
E	4.00"	4.50"
W	9.25"	10.5"
Net Weight	18	28

Note: Meter couplings are optional and must be ordered separately. Weights are in pounds and are approximate.

500 SERIES

Magnetic Drive Positive Displacement Disc Meters Sizes 1 1/2" & 2" Parts

REF NO.	DESCRIPTION	MATERIAL	562 1 1/2" MODEL	572 2" MODEL
1	Visual Register	US Gallons Glass / Brass	D357715	D358115
		CF Glass / Brass	D357725	D358125
	ME-8 and SSR Register*	US Gallons Plastic / Brass / Glass	GWESGxxxx562	GWESGxxxx572
		CF Plastic / Brass / Glass	GWECFxxxx562	GWECFxxxx572
Specify Electronic Reading Value				
2	Complete Register Housing Assembly Includes parts 3-7	Plastic	B7856	B7856
		Bronze	B7857	B7857
3	Visual Register Cover	Plastic	C5768	C5768
		Bronze	C5774	C5774
4	Visual Spiral Pin	Plastic cover: SST	AS41122	AS41122
		Bronze Cover: SST	AS41123	AS41123
5	Visual Register Housing Base	Plastic	C5769	C5769
		Bronze	C5772	C5772
6	Register Housing Insert	Plastic	C5770	C5770
7	Register Locking Pin	Blue Colored Plastic	A12658	A12658
		Brass Colored Plastic	A126581	A126581
8**	Top Case 2 Bolt Flange	Low Lead Bronze	D3546SI	D3550SI
9**	Case Bolts for 2 Bolt Flange Units	SST	90026 (qty 6)	90010 (qty 8)
10	O-ring Case Seal	Rubber	A130206	A130207
11	Top Chamber Assembly		D3275ASSY	D3277ASSY
12	Chamber Retainer	Plastic	C5466	C5466
13	O-ring Chamber Seal	Rubber	A130204	A130205
14	Thrust Roller	SST	A12781	B8024
15	Wear Plate	SST	B8026	B8025
16	Disk Assembly	Plastic / SST	B8067	B8068
17	Bottom Chamber	Plastic	D3274	D3276
18	Chamber Assy Replacement Kit (incl. 10-17)		D3575	D3576
19	Strainer	Plastic	C6576	C6577
20	Test Plug	SST	59013	59013
21	Bottom Case 2 Bolt Flange	Low Lead Bronze - test port	D35481SI	D35521SI

Call Mueller Customer Service for Appropriate ME-8 or SSR Register and AMR/AMI Device part number *Not shown.

ME-8 and SSR register component parts are available on the appropriate data sheets.

500 SERIES

Magnetic Drive Positive Displacement Disc Meters Models 562 and 572

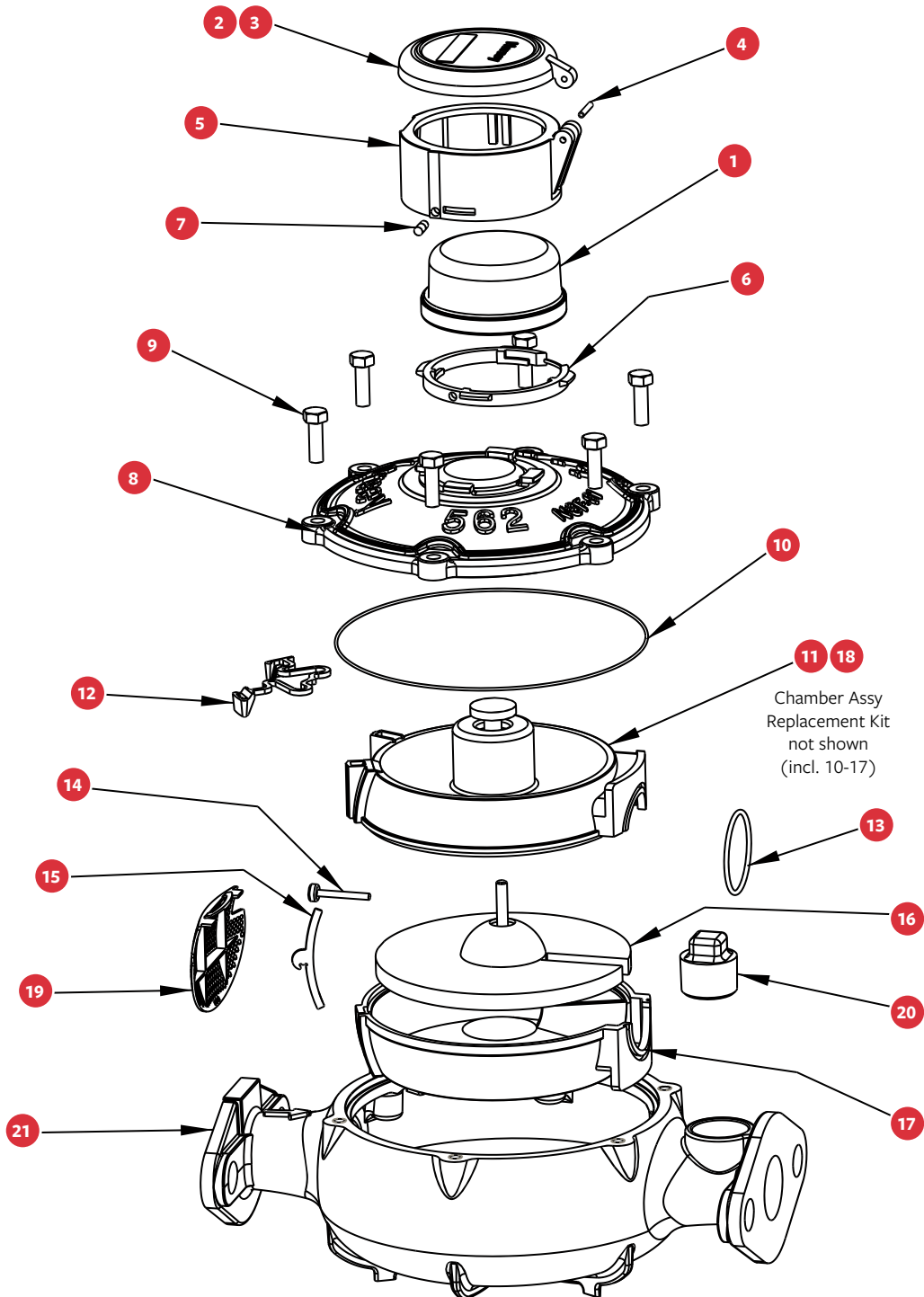

For more information about Mueller or to view our full line of water products, please visit muellersystems.com or call Mueller customer service at 1.800.423.1323.

Mueller refers to one or more of Mueller Water Products, Inc. a Delaware corporation ("MWP"), and its subsidiaries. MWP and each of its subsidiaries are legally separate and independent entities when providing products and services. MWP does not provide products or services to third parties. MWP and each of its subsidiaries are liable only for their own acts and omissions and not those of each other. MWP brands include Mueller®, Echologics®, Hydro Gate®, Hydro-Guard®, HYMAX®, Jones®, Krausz®, Mi.Net®, Milliken®, Pratt®, Singer®, and U.S. Pipe Valve & Hydrant. Please see muellerwp.com/brands and krauszusa.com to learn more.

Copyright © 2021 Mueller Systems, LLC. All Rights Reserved. The trademarks, logos and service marks displayed in this document are the property of Mueller Water Products, Inc., its affiliates or other third parties. Products above marked with a section symbol (§) are subject to patents or patent applications. For details, visit www.mwppat.com. These products are intended for use in potable water applications. Please contact your Mueller Sales or Customer Service Representative concerning any other application(s).

F 14212 5/21

